

EASY PROJECTS FOR CHARITY DONATIONS

Here are instructions for an easy baby quilt and a pillowcase, perfect for **Dr. Fraser's Kids**.

Select 3 high contrast fabrics for the quilts...either in color, values or size of prints. Other small quilt patterns may be used for Dr. Fraser's Kids, and any pillowcase pattern is OK ... these are just to get you started.

Pillowcases do not need to match the quilts.

Please use French seams or serge the seams on the pillowcases. They will be used for carrying a child's belongings as well as a pillow cover.

SUPER-sized 9-Patch (approx. 36" x 41")

Originated by Anita Grossman Solomon www.makeitsimpler.com
 Pattern diagrams and more info available at: www.quiltmaker.com/patterns

3 yards of fabric = 3 quilt tops
 (each quilt will need just one yard each for the backing,
 so you can make 3 quilts with 6 yards total)

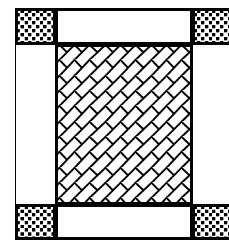

1. Mark an 18" x 21" rectangle on a large cutting mat. Use masking tape or chalk.
2. Fold 1 yd. of fabric into quarters, making first fold lengthwise (as on the bolt). Press lightly.
3. Put the folded corner in the lower left of the marked rectangle.
4. Cut the raw edges off so **the folded piece measures 18" x 21"**.
DO NOT MOVE THE FABRIC during any of the remaining cutting!
5. From the top edge, measure down 9" and cut across the folded fabric (horizontal cut).
6. From the right side measure 9" in and cut top to bottom.
7. You have: 4—9" squares for the corners
 1 center panel 18" x 24"
 2 side borders 9" x 24"
 and a top & bottom border 9"x18".
8. Repeat the cutting with 2 more fabrics.
9. Mix & match the pieces to make 3 quilt tops.

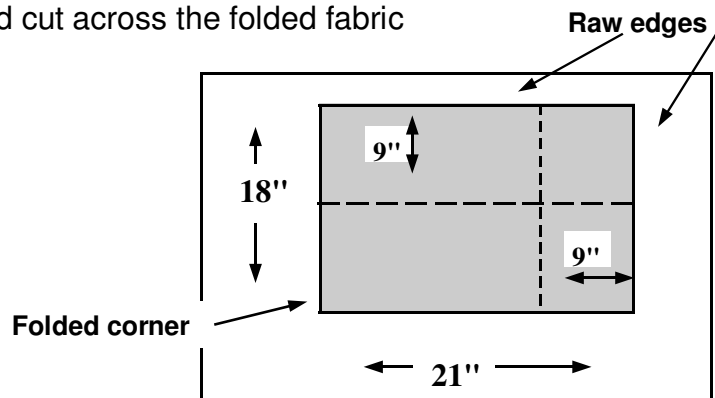

Pillowcase Instructions

Case: 7/8 yd. (cut 27" x Width Of Fabric) a non-directional print is best

Accent: 1 1/4" strip WOF

Cuff (hem): 1/3 yd. (cut strip any width between 9" and 11" x WOF)

1. Sew Accent strip to Cuff strip.
2. Sew Accent edge to one long edge of case. If any part is too long, just trim it off after sewing.
3. With Right Side up, start at the bottom of the Case, roll toward Cuff.
3. Place rolled Case on Cuff RS, then match Accent/Case seam to long raw edge of Cuff.
The Case is inside the Cuff, the Cuff is now Wrong Side out.
4. Sew right on top of the Accent/ Case seam or just outside the seam allowance. Try not to catch the rolled Case in the seam.
5. Pull the case out of the Cuff, through one short end. This turns the Cuff RS out, too.
6. Finish sewing the case sides with a French seam (sew WS together then sew RS together) or serge.
Start sewing at the Cuff for a better match.

You can make this pillowcase without the Accent strip.